



FMB-24N70.2C
(SB50+M12-F)

Connector options:



AS150U



Weipu 7P

Charged by



Features

- Data Visibility – APP – Integrated with Battery
- Made in Europe
- BMS with auto on/off hibernate function, no quiescent current draw
- Scalable up to 16pcs in parallel, Engineered for hot swapping
- Automatic Master/Slave CAN protocol with virtual master
- Battery parameter logger
- Battery performance and lifetime optimizer based on all battery values for charging/discharging
- Battery heater - Optional
- 2 years warranty

Applications

- Electric mobility
- Industry
- Energy storage

For additional information, please visit <https://meanwellpowersupplies.com/>

Description

The FMB series from MEAN WELL EUROPE is designed for multipurpose use within i-ion 7S (24V), 14S (48V), and 17S (60V) battery setups. This battery is suitable for parallel operation. Due to the modular concept, it is possible to suit the battery with different types of connectors and with or w/o a digital indicator, CAN or wireless connectivity and an IoT database connection. The efficient electronics make it possible to store the battery for over 2 years without recharging.

Model Encoding / Order Information

FMB - 24 N 70.2 -

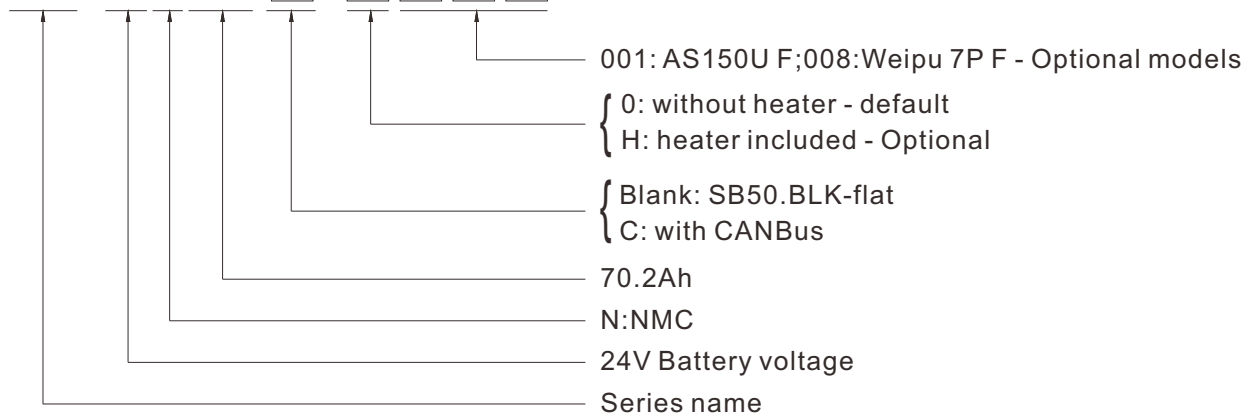

Part Number	Battery Description	Note
FMB-24N70.2	Battery NMC 7S 24V 70.2Ah, SB50.BLK-flat	In Stock
FMB-24N70.2C	Battery NMC 7S 24V 70.2Ah, SB50.BLK-flat +M12-F	In Stock
FMB-24N70.2C-0001	Battery NMC 7S 24V 70.2Ah, AS150U F	In Stock
FMB-24N70.2C-0008	Battery NMC 7S 24V 70.2Ah, Weipu 7P F	In Stock

*C: With CANBus

1. Product specifications

Item	Value	Remark
Product category	Lithium batteries	
Product name	Battery Li-ion 7S 24V 70.2Ah FMB	
Weight	10.2 Kg	
Dimensions	265 x 74 x 410 mm	(LxWxH)
Voltage nominal	25.2 V	
Voltage max	29.4 V	
Voltage min	21.0 V	
Capacity Ah	70.2 Ah	
Discharge current continuous	50A	
Discharge current peak	100A	3 sec
Typical charge current	12A	
Max charge current	15A - without CANBus	*Specified max charge current can be 35A with CAN controlled charge algorithms.
Charge method	CC/CV	
Operating temperature; charge	0 ~ 45°C	
Operating temperature; discharge	-10 ~ 65°C	
Storage temperature	-20 ~ 60°C	

*Please contact the specialists of MEAN WELL EUROPE for the details. CANBus charger is necessary.

2. Cell specifications

Item	Value	Remark
Cell type	DMEGC 18650-26E	
Nominal voltage cell	3.60 V	
Cell capacity	2,600 mAh	@0.05C
CID	Yes	
Cells in series	7	
Cells parallel	27	

3. BMS specifications

Item	Value	Remark
Cell auto balance	Yes, 72±10mA	
Short circuit protection	Yes	
Temperature protection	Yes	
Overcharge protection	Yes, 4.28±0.025V	
Over discharge protection	Yes, 3.00±0.05V	
Over current protection	Yes, 120A±20A	
Self power consumption	30-100uA	

4. BMS specifications

The control PCB is an add-on for the BMS, making the battery "smart". This PCB gathers all applicable data and processes it for wireless or CAN communication. To save energy and increase shelf life, this control PCB will shut down when the battery SOC < 50% and the battery is not used for 25 hours. To wake up, one of the following actions should be performed: The battery key switch* must be pulled high, the button pressed or a current of 2+Amp must be drawn by charging or discharging.

*if installed

5.Connectors and terminals

The FMB series is designed to be fitted with different types of connectors, depending on the application. MEAN WELL EUROPE offers two standard part-numbers for 70.2Ah battery pack, others may be discussed.

P/N	Value	Remark
FMB-24N70.2	Anderson SB50/BLK - flat connector	Power only
FMB-24N70.2C	Anderson SB50/BLK - flat connector + M12-Female/A coded/5-pins	Power and CANbus
FMB-24N70.2C-0001	AS150U F 1(KEY) 2(CAN high) 3(CAN low) 4(NC)	Power and CANbus
FMB-24N70.2C-0008	Weipu 7P F 1,2(BAT+) 3(optional) 6,7(BAT-) 4(CAN HIGH) 5(CAN LOW)	Power and CANbus

6.Enclosure

Item	Value	Remark
Material	PC/ABS/fiber reinforced PC/Aluminum	
FR Class (UL-94)	HB	Or better

7.Safety

Item	Value	Remark
IEC62133-2	Yes	
MSDS	Yes	
UN 38.3	Yes	
CE	Yes	
Temperature protection	Yes	1x digital + 2x analog

8.CAN-bus (optional)

MEAN WELL Europe provides good local service, and the design house can fit a basic CAN-bus feature, compliant with different CAN-bus protocol suited for parallel (hot-swap) operation. A detailed CANbus guide is available for protocol instructions. To give the complete solution, MEAN WELL smart charger is 100% compatible with the lithium battery packs.

Note: For swappable systems it is advised to put an ESD protection in your CANbus, e.g. a TSV diode.

P/N	Value	Remark
Baudrate	250Kbps - default setting	500Kbps is optional
CANBus	CAN2.0B, CANOpen	
Data format	Little endian	
Data type	Unsigned	
Node-ID	15	
Available data basic protocol	Battery status	Ready, Disengaged, Charging, Discharging, Preheating, Error
	SOC	%
	Voltage	V
	Current	A
	Battery temperature	°C
Available data advanced protocol (suitable for parallel stacked battery setup)	Pack status	Ready, Disengaged, Charging, Discharging, Preheating, Error
	Pack SOC	%
	Pack voltage	V
	Pack current	A
	Pack max temperature	°C
	Pack min temperature	°C
	Active batteries in the pack	#
Passive batteries in the pack	#	
Individual battery data request (advanced protocol only)	Battery ID	#
	Lowest lifetime voltage	V
	Highest lifetime voltage	V
	Cycle life	#
	Number of deep discharges	#
	Number of subzero charges	#

9. Wireless connectivity data (optional)

MEAN WELL EUROPE offers an in-house built smart phone application that may be altered upon client request.

P/N	Value	Remark
Current status	Battery status ^{basic}	Ready, Disengaged, Charging, Discharging, Preheating, Error
	State of charge ^{basic}	0-100%
	Voltage ^{basic}	V
	Current ^{basic}	A
	Outside (ref) temperature ^{basic}	°C
	Battery temperature	°C
Battery healthcare	Deep discharges	#
	Subzero discharges	#
	Min voltage	V
	Max voltage	V
	Max humidity level (water damage)	Level between 1-100
	Max charge current	A
	Max discharge current	A
History	Cycle life ^{basic}	#
	Used energy (Wh) over last 5 runs	A run is defined as the period between two charge events that last at least 8 seconds
multiple parallel battery packs status (optional, combined with CANbus)	Short ID	Battery ID starting at 1
	Pack state	Same as "Battery status", but for the whole parallel pack
	Pack SOC	%
	Pack current ^{basic}	A
	Number of active packs ^{basic}	#
	Number of passive packs ^{basic}	#
	Pack highest temperature	°C
	Pack lowest temperature	°C

Items marked with ^{basic} are available in our free app "**Charged by MEAN WELL**", available in the Apple app store and Google Play store. MWEU offers custom apps for commercial use.

10. IoT (optional)

With the optional wireless module all battery data can be sent to a secured server of AWS (Amazon Web Services) and stored in a NoSQL format database (MongoDB). Data may only be shared upon customer request.

Disclaimer:

MEAN WELL EUROPE offers datasheet information "provided as is" without any warranty. In the event of discrepancies, the datasheets will govern (please refer to <https://meanwellpowersupplies.com/> for the most current versions).

MEAN WELL EUROPE disclaims any liability for claims arising from inaccuracies in the datasheets. Customers are encouraged to carefully evaluate the suitability of our products prior to placing orders.

We reserve the right to update datasheet information without prior notice, ensuring our commitment to excellence and innovation.

MECHANICAL SPECIFICATION

Unit:mm

FMB-24N70.2

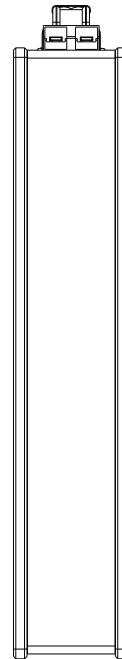
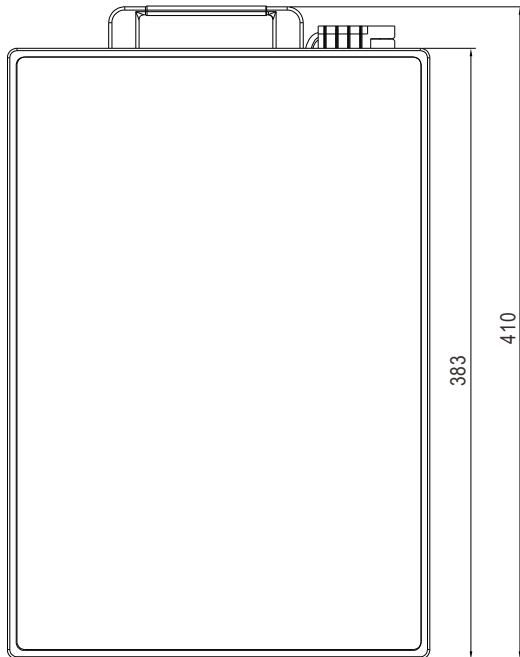
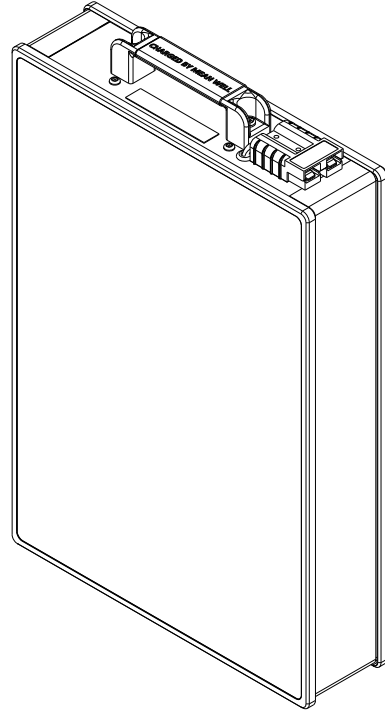
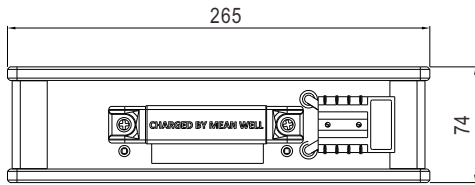

Unit:mm

FMB-24N70.2C

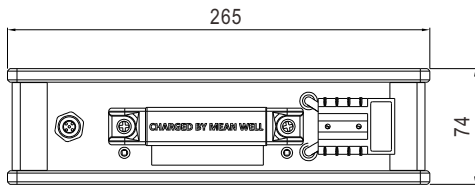

M12-F, A-coded, 5-pins
1(NC) 2(KEY) 3(NC) 4(CAN HIGH) 5(CAN LOW)



*The "KEY" is an input pin that sends a positive signal (12V or battery voltage) to wake up the intelligent layer from hibernation mode.

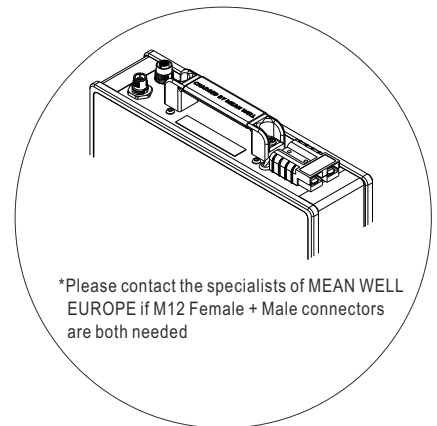
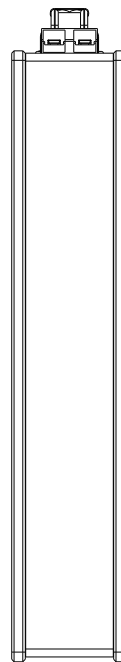
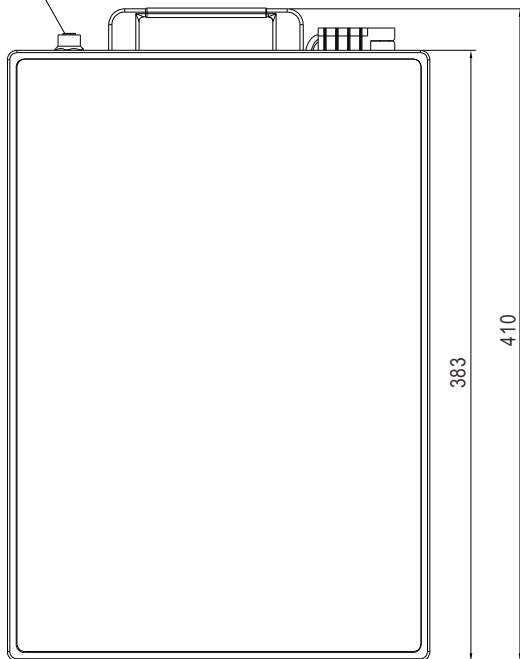
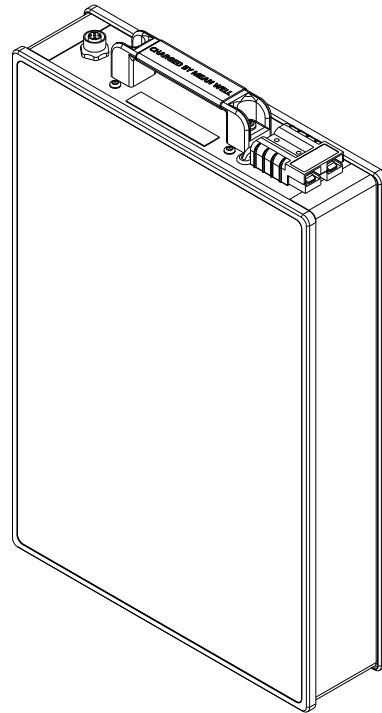

Unit:mm

FMB-24N70.2C-0001

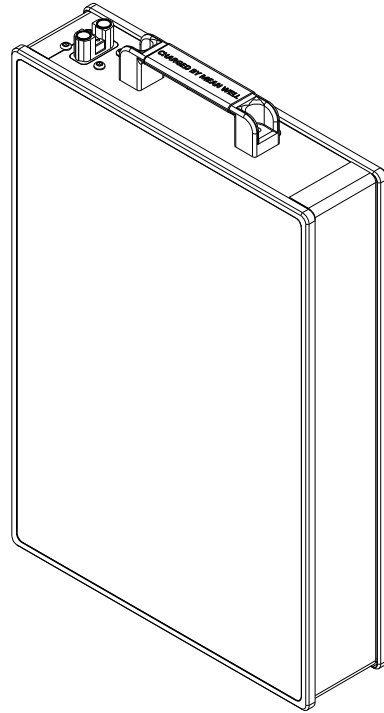
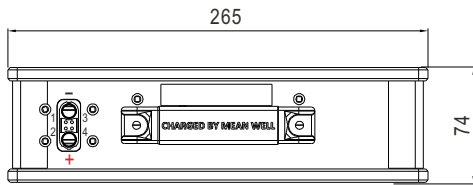

AS150U F
1(KEY) 2(CAN high) 3(CAN low) 4(NC)



*The "KEY" is an input pin that sends a positive signal (12V or battery voltage) to wake up the intelligent layer from hibernation mode.

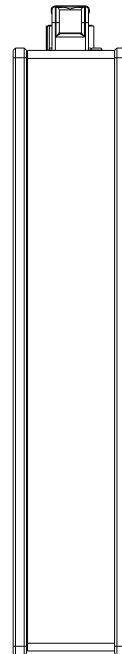
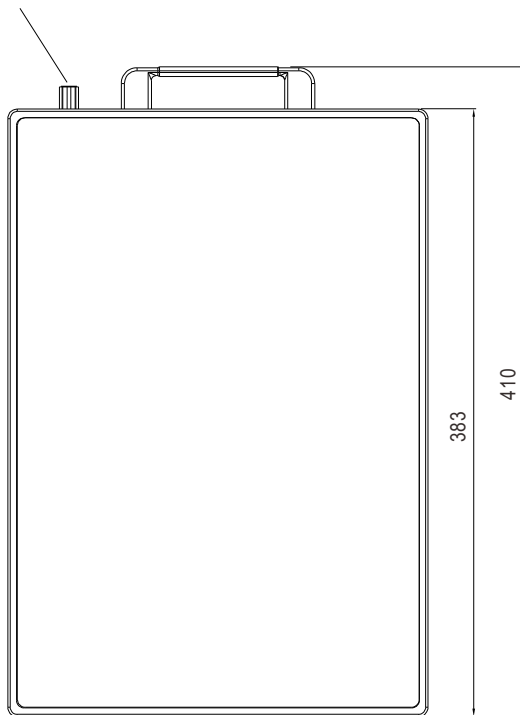

Unit:mm

FMB-24N70.2C-0008

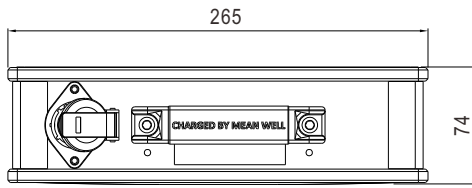

Weipu 7P F
1,2(BAT+) 3(optional) 6,7(BAT-) 4(CAN HIGH) 5(CAN LOW)

