



QHB-48N33.8C
(XLR+3P+M12-F)



Connector options:



AS150U



Features

- Data Visibility – APP – Integrated with Battery
- Made in Europe
- Mounting in any position
- Durable design- IP67
- BMS with auto on/off hibernate function, no quiescent current draw
- Battery parameter logger
- Battery performance and lifetime optimizer based on all battery values for charging/discharging
- 2 years warranty

Applications

- Electric mobility
- Boating
- Industry
- Mobile energy supply

For additional information, please visit <https://meanwellpowersupplies.com/>

Description

The QHB series from MEAN WELL EUROPE is designed for multipurpose use within li-ion 7S-13S (24V-48V) and LiFePO4 4S (12V) battery setups. The durable design, consisting of fiber reinforced plastics, makes this battery suitable for operating in harsh environments. This type of battery is suited with a digital indicator and can be fitted with wireless functionality to read out a broad variety of data.

Model Encoding / Order Information

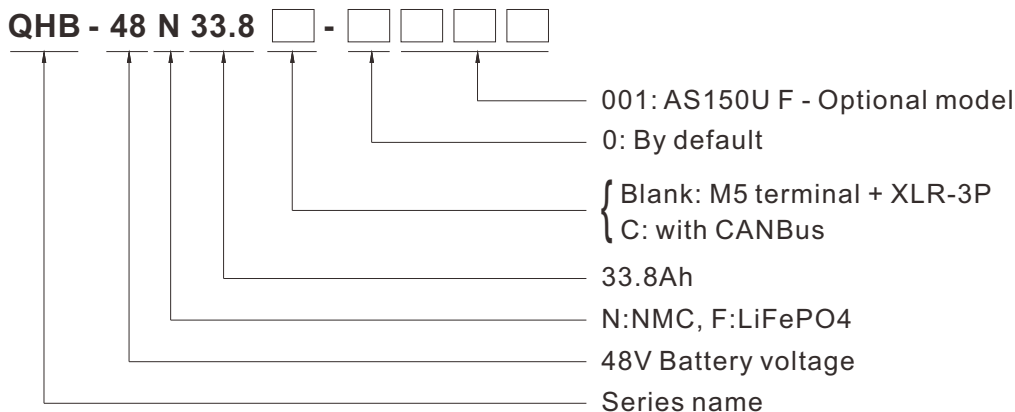

Part Number	Battery Description	Note
QHB-48N33.8	Battery NMC 13S 48V 33.8Ah, M5 terminal + XLR-3P	In Stock
QHB-48N33.8C	Battery NMC 13S 48V 33.8Ah, M5 terminal+XLR-3P+M12-F	In Stock
QHB-48N33.8C-0001	Battery NMC 13S 48V 33.8Ah, AS150U F	In Stock

*C: With CANBus

1. Product specifications

Item	Value	Remark
Product category	Lithium batteries	
Product name	Battery Li-ion 13S 48V 33.8Ah QHB	
Weight	10.75 kg	
Dimensions with bumpers	197 x 167 x 296.5 mm	(LxWxH)
Dimensions without bumpers	182.8 x 152.8 x 288.5 mm	(LxWxH)
Voltage nominal	46.8 V	
Voltage max	54.6 V	
Voltage min	37.7 V	
Capacity Ah	33.8Ah (max)	
Discharge current continuous	50A	
Discharge current peak	100A	3 sec
Max charge current	10A-without CANBus	*Specified max charge current via battery terminals can be 15A with CAN controlled charge algorithm, for "C" version of battery
Charge method	CC/CV	
Operating temperature; charge	0 ~ 45°C	
Operating temperature; discharge	-10 ~ 65°C	
Storage temperature	-20 ~ 60°C	

*Please contact the specialists of MEAN WELL EUROPE for the details. CANBus charger is necessary.

2. Cell specifications

Item	Value	Remark
Cell type	DMEGC 18650-26E	
Nominal voltage cell	3.60 V	
Cell capacity	2,600 mAh	@0.05C
CID	Yes	
Max Current	3C	
Cells in series	13	
Cells parallel	13	

3. BMS specifications

Item	Value	Remark
Cell auto balance	Yes, 72±10mA	
Short circuit protection	Yes	
Temperature protection	Yes	Bi-metal sensors
Overcharge protection	Yes, 4.28±0.025V	
Over discharge protection	Yes, 3.00±0.05V	
Over current protection	Yes, 120A±20A	

4. Control PCB

The control PCB is an add-on for the BMS, making the battery "smart". This PCB gathers all applicable data and processes it for wireless or CAN communication. To save energy and increase shelf life, this control PCB will shut down when the battery SOC < 50% and the battery is not used for 25 hours. To wake up, one of the following actions should be performed: The battery key switch* must be pulled high, the button pressed or a current of 2+Amp must be drawn by charging or discharging.

*if installed

5.Connectors and terminals

Item	Value	Remark
Terminal material	Brass, silver plated	
Terminal dimensions	M5 inner thread	
QHB-48N33.8C	XLR-F 3P	1(+), 2(-), 3(NC)
	M12-F, A-coded, 5-pins	Please see pin assignment on the page of Mechanical Specification
QHB-48N33.8C-0001	AS150U F	1(KEY) 2(CAN high) 3(CAN low) 4(NC)

6.Enclosure

Item	Value	Remark
Material	PC/ABS/fiber reinforced/Rubber	
FR Class (UL-94)	HB	Or better

7.Safety

Item	Value	Remark
IEC 62133-2	Yes	
MSDS	Yes	
UN 38.3	Yes	
CE	Yes	
IP	IP65-67 rated, compliance	Depends on the options of connector
Temperature protection	Yes	1x digital + 2x analog

8.CAN-bus (optional)

MEAN WELL Europe provides good local service, and the design house can fit a basic CAN-bus feature, compliant with different CAN-bus protocol suited for parallel (hot-swap) operation. A detailed CANbus guide is available for protocol instructions. To give the complete solution, MEAN WELL smart charger is 100% compatible with the lithium battery packs.

Note: For swappable systems it is advised to put an ESD protection in your CANbus, e.g. a TSV diode.

P/N	Value	Remark
Baudrate	250Kbps- default setting	500kbps is optional
CANBus	CAN2.0B, CANOpen	
Data format	Little endian	
Data type	Unsigned	
Node-ID	15	
Available data basic protocol	Battery status	Ready, Disengaged, Charging, Discharging, Preheating, Error
	SOC	%
	Voltage	V
	Current	A
	Battery temperature	°C
Available data advanced protocol (suitable for parallel stacked battery setup)	Pack status	Ready, Disengaged, Charging, Discharging, Preheating, Error
	Pack SOC	%
	Pack voltage	V
	Pack current	A
	Pack max temperature	°C
	Pack min temperature	°C
	Active batteries in the pack	#
	Passive batteries in the pack	#
Individual battery data request (advanced protocol only)	Battery ID	#
	Lowest lifetime voltage	V
	Highest lifetime voltage	V
	Cycle life	#
	Number of deep discharges	#
	Number of subzero charges	#

9. Wireless data (optional)

MEAN WELL EUROPE offers an in-house built smart phone application that may be altered upon client request.

P/N	Value	Remark
Current status	Battery status ^{basic}	Ready, Disengaged, Charging, Discharging, Preheating, Error
	State of charge ^{basic}	0-100%
	Voltage ^{basic}	V
	Current ^{basic}	A
	Outside (ref) temperature ^{basic}	°C
	Battery temperature	°C
Battery healthcare	Deep discharges	#
	Subzero discharges	#
	Min voltage	V
	Max voltage	V
	Max humidity level (water damage)	Level between 1-100
	Max charge current	A
	Max discharge current	A
History	Cycle life ^{basic}	#
	Used energy (Wh) over last 5 runs	A run is defined as the period between two charge events that last at least 8 seconds
Multiple parallel battery packs status (optional, combined with CANbus)	Short ID	Battery ID starting at 1
	Pack state	Same as "Battery status", but for the whole parallel pack
	Pack SOC	%
	Pack current ^{basic}	A
	Number of active packs ^{basic}	#
	Number of passive packs ^{basic}	#
	Pack highest temperature	°C
	Pack lowest temperature	°C

Items marked with ^{basic} are available in our free app "**Charged by MEAN WELL**", available in the Apple app store and Google Play store. MWEU offers custom apps for commercial use.

10. IoT

With the optional wireless module all battery data can be sent to a secured server of AWS (Amazon Web Services) and stored in a NoSQL format database (MongoDB). Data may only be shared upon customer request.

Disclaimer:

MEAN WELL EUROPE offers datasheet information "provided as is" without any warranty. In the event of discrepancies, the datasheets will govern (please refer to <https://meanwellpowersupplies.com/> for the most current versions).

MEAN WELL EUROPE disclaims any liability for claims arising from inaccuracies in the datasheets. Customers are encouraged to carefully evaluate the suitability of our products prior to placing orders.

We reserve the right to update datasheet information without prior notice, ensuring our commitment to excellence and innovation.

MECHANICAL SPECIFICATION

Unit:mm

QHB-48N33.8

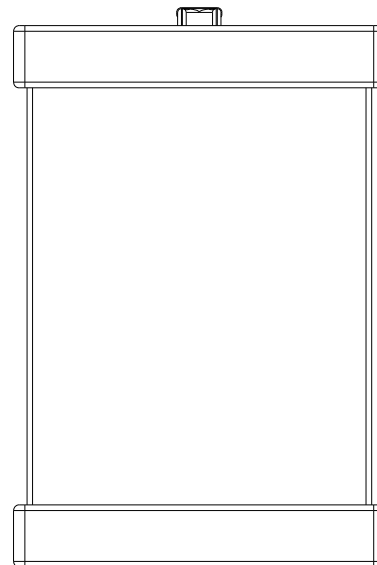
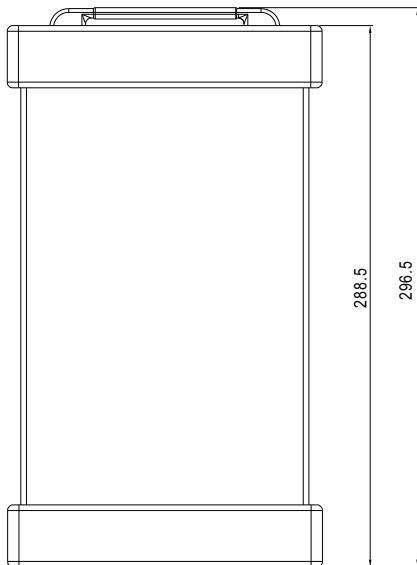
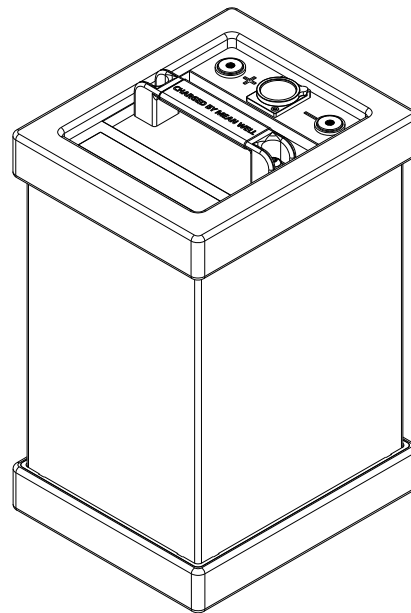
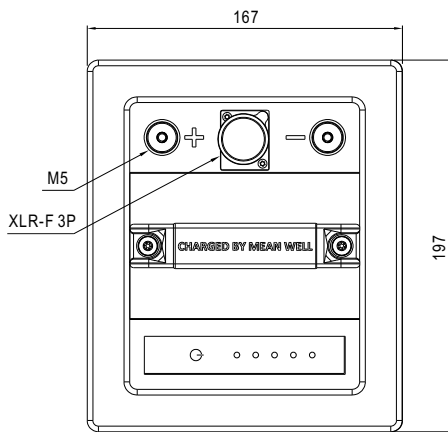
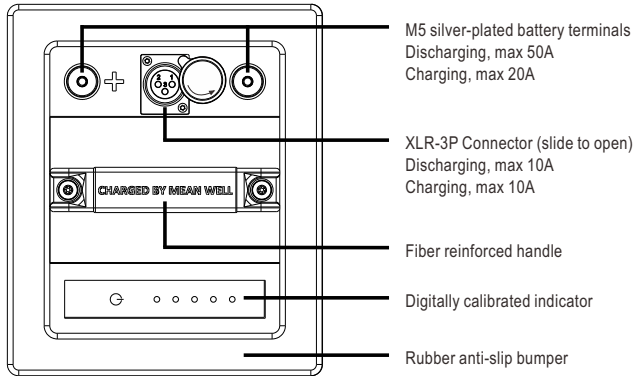

Unit:mm

QHB-48N33.8C

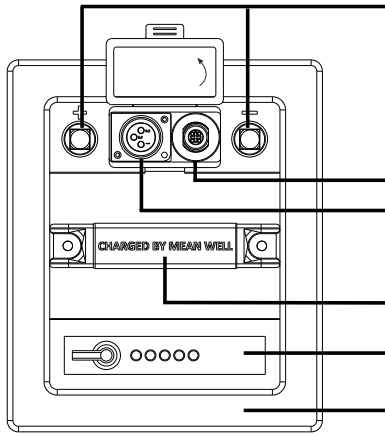

M5 silver-plated battery terminals
Discharging, max 50A
Charging, max 20A



1(NC) 2(KEY) 3(NC) 4(CAN HIGH) 5(CAN LOW)

*The "KEY" is an input pin that sends a positive signal (12V or battery voltage) to wake up the intelligent layer from hibernation mode.

M12-F
XLR-3P Connector (slide to open)
Discharging, max 10A
Charging, max 10A

Fiber reinforced handle

Digitally calibrated indicator

Rubber anti-slip bumper

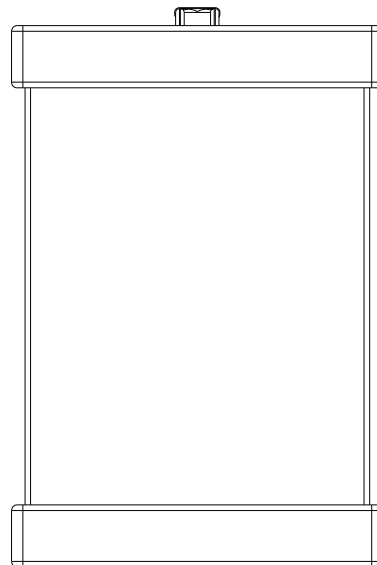
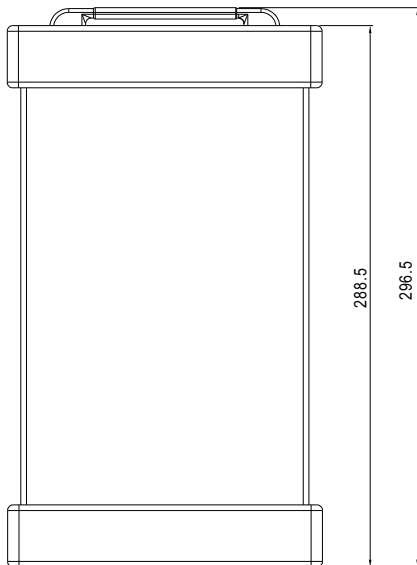
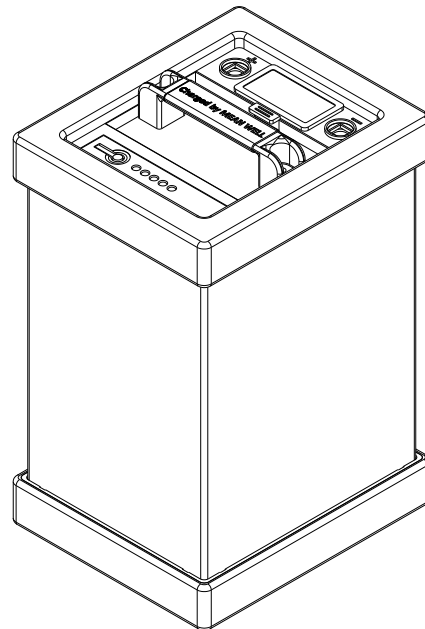
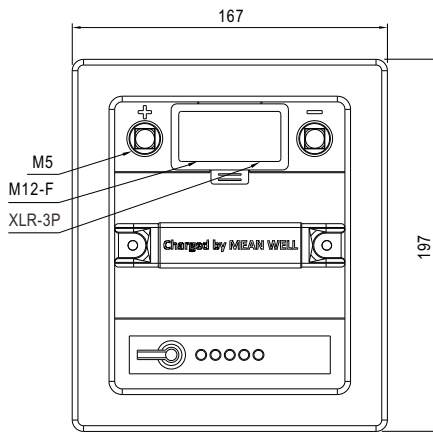

Unit:mm

QHB-48N33.8C-0001

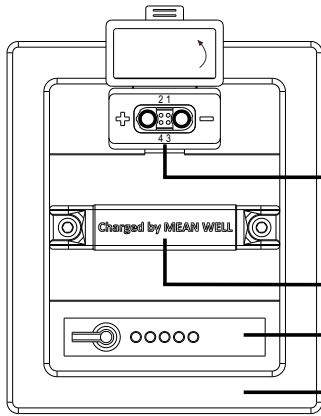

1(KEY) 2(CAN high) 3(CAN low) 4(NC)

*The "KEY" is an input pin that sends a positive signal (12V or battery voltage) to wake up the intelligent layer from hibernation mode.

